



# SW-1W SERIES

## Washdown Portion Control Scale

The SW-1W Series is an easy to use portion control scale, great for use in restaurants, meat & poultry plants, bakeries, farmer's markets, and more. Achieve precise measurements with the SW-1W's dual range technology. Its simple interface allows you to switch units easily to lbs, oz, kg, or g.

- Easy to Clean - Washdown - Up to IP66 Standards
- Portable
- Legal for Trade



# SW-1W SERIES | Washdown Portion Control Scale

## FEATURES

- Washdown to IP66 Standards
- AC or Battery Operated
- Large Easy to Read 1 Inch LCD Display
- Lb/g/kg/oz Switchable
- Precise Measurements with Dual Range Technology
- **Soft Touch Tactile Keyboard**
- Stainless Steel Platter
- **Auto Power Off**
- Warranty - 1 Year

## WASHDOWN



The **SW-1W** is protected from water, dirt and other external agents, up to IP 66 Standards.

Use in any environment where washdown cleaning is necessary, from kitchens, bakeries, cafeterias, delis, and more.



Optional Rear Display



Battery Compartment

## SPECIFICATIONS

Model	SW-10W	SW-20W	SW-50W	
Weighing Capacity	lb	4/10 lb	10/20 lb	25/50 lb
		0.002/0.005	0.005/0.01	0.01/0.02
	oz	80/160 oz	200/400 oz	320/800 oz
		0.05/0.1	0.1/0.2	0.2/0.5
	kg	2.5/5 kg	5/10 kg	10/20 kg
		0.001/0.002	0.002/0.005	0.005/0.01
g	2500/5000 g	5,000/10,000 g	10,000/20,000 g	
	1/2	2/5	5/10	
Display Digit	5 Digit LCD (1 Inch)			
Display Designators	Stable, Zero, Net, Batt			
Keys	Zero, Tare, Unit, Power			
Measurement Type	Load Cell			
Power Source	DC 9V (6 - "D" Size Batteries) / 9V AC Adapter Included AC Adapter Not Washdown			
Power Consumption	0.25 W			
Operating Time	Alkaline Dry Battery: 1000 hr			
Operating Temp	-10°C ~ 40°C / 14°F ~ 104°F			
Platter Size (in/mm)	SW-1W	9.75 (W) x 7.75 (D) / 248 (W) x 197 (D)		
	Lg Platter	14 (W) x 12 (D) x 2 (H) / 356 (W) x 305 (D) x 51 (H)		
Dimensions (inch/mm)	11 (W) x 12.5 (D) x 5 (H) / 279 (W) x 318 (D) x 127 (H)			
Product Weight	7.3 lbs / 3.3 kg			
Approvals	NTEP COC# 09-075			



## DIMENSIONS

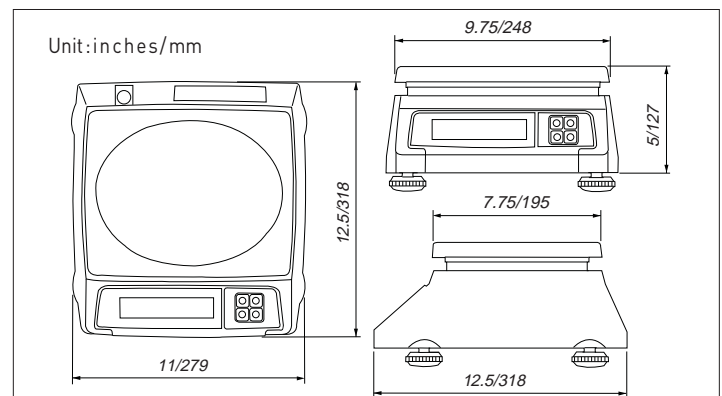

# CAS

99 Murray Hill Parkway  
East Rutherford, NJ 07073

TEL: (201) 933-9002

FAX: (201) 933-9025

<http://www.cas-usa.com>

Specifications are subject to change for improvement without prior notice.