



The Best in Portable Drum and Barrel Scales... *Run-A-Weigh*



Cardinal's *Run-A-Weigh* lets you put a platform scale where you need it, when you need it.

Weighing in at less than 100 pounds and featuring built-in handles and wheels, the *Run-A-Weigh* is easy to lift and roll to wherever you need it. Whether it's multiple weighing locations at a single facility or the need to take a scale to special job sites, the *Run-A-Weigh* gives you true portability.



Stainless Steel Run-A-Weigh

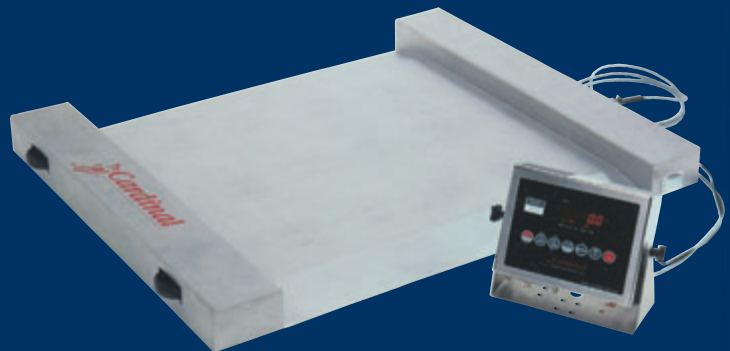

With Cardinal's 205 Weight Indicator
For Weighing Applications In Harsh Environments



Choose The Weighing System To Fit Your Requirements

If you need a general purpose scale, a scale for tough environments, or a scale for washdown applications, Cardinal has the right system for you. We offer enclosures in stainless steel or stainless steel NEMA 4X/ IP66.



Available in Your Choice of Standard or Stainless Steel

Model RW-100
with 204 Indicator



Built-in wheels permit the scale to be rolled anywhere it's needed.

Stainless Steel
with 205 Indicator

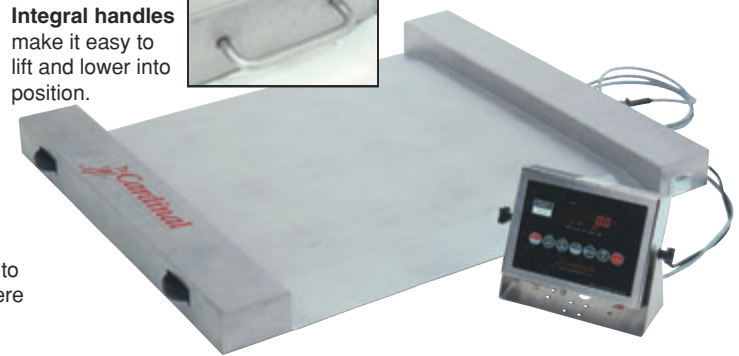

Integral handles make it easy to lift and lower into position.

Cardinal's "Run-A-Weigh" . . . So Portable You Can Use It *Anywhere and Everywhere!*

Designed for weighing "on-the-move," this portable scale features a Cardinal Digital Weight Indicator that can be mounted on the wall or desk for convenient viewing. Setup is simple and quick with the *Run-A-Weigh's* self-aligning feet. Heavy-duty construction, large checkered safety plate platform with integral ramps, and the 500 lb or 1,000 lb capacity make this the perfect scale for weighing barrels, drums, and small crates - *anywhere!*

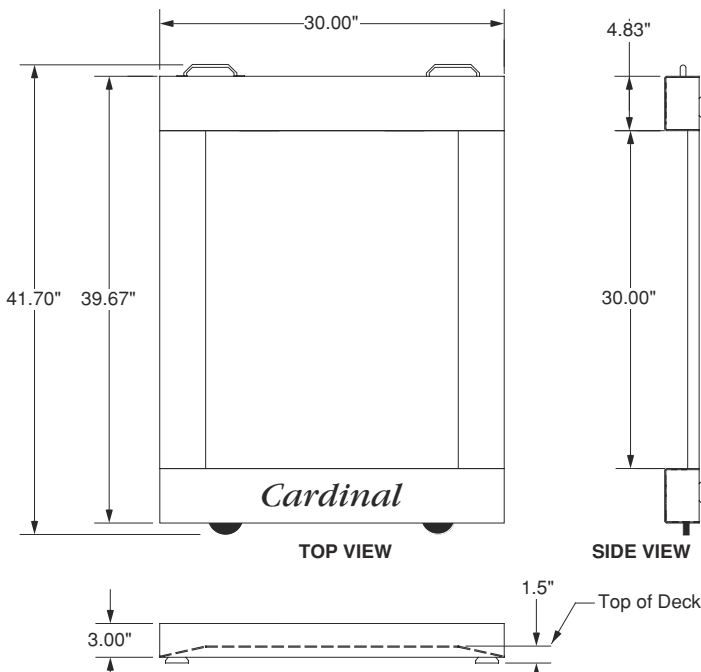

Cardinal Scale reserves the right to improve, enhance or modify features and specifications without prior notice.

Specifications

Capacity:	RW-1000 1000 lb x 0.5 lb/450 kg x 0.2 kg
	RW-500 500 lb x 0.2 lb/225 kg x 0.1 kg
Dimensions:	30"L x 40"W x 4 1/2"H (76 cm x 102 cm x 11.5 cm)
Platform:	30"L x 30"W x 2 1/2"H (76 cm x 76 cm x 6.4 cm) checkered safety plate
Construction:	Heavy-duty steel with baked-on, powder paint finish
Shipping Weight:	105 lb
204 Indicator	
Display:	5 digit, 7 segment, .1" high LCD
Units Conversion:	Keypad selectable
Enclosure:	General purpose, stainless steel
Power:	Six "C" cell or NiCad batteries, standard 12VDC (115 VAC 60 Hz adapter) or 115 VAC 60 Hz
Output:	RS-232
Zero Tracking:	.0 to 4% selectable ± 6 or 1d selectable 4% max. range
Temperature Range:	14 °F to +104 °F (-10 °C to +40 °C)
205 Indicator	
Display:	6-digit, 7-segment LED, 14mm/0.6" H
Units Conversion:	Lb, lb/oz, oz, kg, g,
Enclosure:	NEMA 4X stainless steel
Power:	90 to 260 VAC, 50 or 60 Hz
Output:	RS-232
Temperature Range:	14 °F to +104 °F (-10 °C to +40 °C)
	• LED annunciators • Auto shutoff mode • Keyboard setup and calibration

Sold By:

Cardinal
Cardinal Scale Manufacturing Co.

P.O. Box 151, Webb City, MO 64870 USA
Ph: 417-673-4631 or 800-441-4237 • Fax: 417-673-5001
www.cardinalscale.com

© Copyright 2002 Cardinal Scale Mfg. Co. • Printed in USA • MWC/0402/5M/273

ISO
REGISTERED 9001